

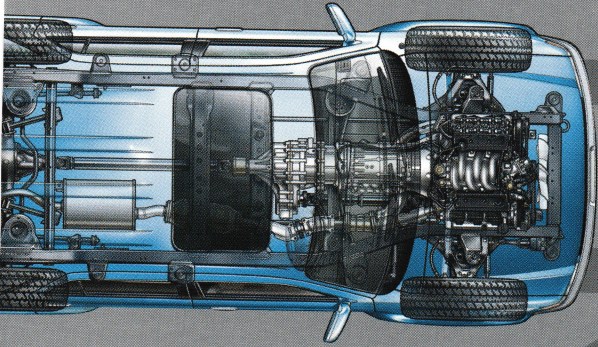

PREMIER PLAN



Drive with confidence, coast-to-coast, knowing that your vehicle is covered by one of the most comprehensive aftermarket protection plans available anywhere.* And in the unlikely event that there is a problem, you can count on the same award-winning service that has made Preferred Warranties one of the fastest growing Extended Service Contract providers in the U.S.

- Award-winning customer service, with phones answered 24/7
- ASE-certified claims adjusters
- Outstanding record of customer and dealer satisfaction since 1992
- Approved claims paid fast! (5 days or less after the work is completed.)
- Only select dealerships that are known for quality, dependable pre-owned vehicles are approved to offer Preferred Warranties plans

* Listed items are general guidelines only. Please see contract for complete details. A form of contract can be obtained by contacting your dealer or a PWI representative.

WE SUPPORT VOLUNTARY CERTIFICATION THROUGH



IF IT'S NOT ON THE LIST, IT'S COVERED!

(It even includes rental up to 6 days.)

Premier covers everything in all of our other plans – and more. In fact, it's so comprehensive that this "exclusionary" contract lists only the things not covered. In other words, if it's not listed on the contract, IT IS COVERED!*

Your Premier Plan covers practically all factory-installed mechanical and electrical operating parts. The few items not covered are mostly those involved in scheduled services and normal wear and tear, such as:

- Regular maintenance services as recommended by the manufacturer
- Hybrid vehicle battery/electric vehicle battery
- Normal maintenance parts and services such as engine tune-ups, batteries, filters, fluids, A/C refrigerant, hoses and belts, wiper blades, brake pads, tires, wheels and balancing, exhaust system, catalytic converter and manual clutch components
- Window glass, head lamps, trim, moldings, upholstery, convertible tops, paint, sheet metal and flexible body parts, bumpers, door panels and handles, structural framework
- Aftermarket accessories or equipment not installed by the manufacturer
- Repairs to meet emissions standards

* These are general guidelines. See your contract for details.



Check online for claim updates



Help finding a repair shop



Customer service 24/7



Approved claims paid fast

DRIVE WITH CONFIDENCE, COAST-TO-COAST.™